

THE WI-FI PROFESSIONAL BUILDING

8100 McCormick Blvd Skokie, IL 60076



WEISS
PROPERTIES
INCORPORATED



THE WI-FI PROFESSIONAL BUILDING

Through extensive rehabilitation and creative repositioning, what was once a vacant, single-user factory and warehouse is now a highly visible, multi-tenant office building, home to over 30 individual businesses.

Tenants enjoy an array of custom amenities ranging from the technological to the convenient. On premises is a full service cafe, coffee area, and health club. The property is securely monitored by a C.C.T.V. system that has secure electronic doors. Ample on-site parking is provided.

BUILDING AMENITIES

- Full Service Kosher Cafe
 - Fitness Center with Sauna & Showers
 - Conference Facilities
 - Free Gourmet Coffee
 - Tenant Lounge with Free Wifi
 - Tenant Events
 - Onsite Management
 - Abundant Parking
 - Close Proximity to I-94 Downtown Skokie, & Downtown Evanston
-





SUITE 219

Two-room office suite in a cozy loft area right near the building amenities. Perfect space for an individual or a small team.



\$30/SF



345 SF



BUILD TO SUIT

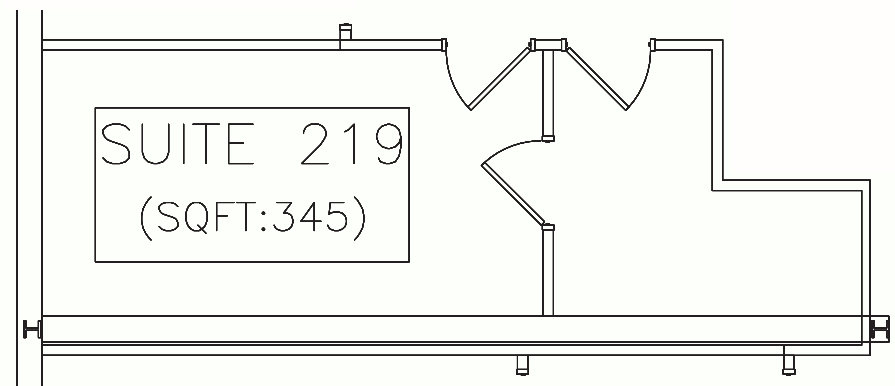



CONTACT

Abe Brimm

Office: 847.329.7600

Cell: 773.852.7607

leasing@weissproperties.com

